

Operation manual
Mechatronic High Speed
Overlock Machine

Tre 04 N
Quattro 24 N
Cinque 35 N

 ***texi***

CONTENTS

Safety precaution	1
User's manual	2
1. Assemble the machine head on table top	4
2. Lubrication	4
3. Manual lubrication	4
4. Filling in cans (grease fitting) devices with silicone oil	5
5. Threading	6
6. Adjusting the presser foot pressure	7
7. Adjusting the differential feed ratio	7
8. Replacing lower knife	8
9. Replacing the needle	9
10. Adjusting stitch length	9
11. Replacing the oil and oil filter	10
12. Adjusting thread tension	11
13. Cleaning the machine	11
Regulation	12
Ask your supplier about	13
Declaration of Conformity	14

SAFETY PRECAUTION

This instruction manual contains important guidelines regarding correct, safe and economical method of use of the machine. Following recommendations contained in this manual will decrease work down-time, increase machine reliability and durability, and will make work safer.

This instruction manual must always be available at the workplace. The machine can be serviced only by an employee trained in Industrial Safety, after reading this instruction manual.

The supplier is not responsible for damages caused by improper use or by usage of this product for functions other than those it has been designed for.

To minimize the risk of fire, electric shock, or injury, observe the following precautions:

- Keep the workplace clean.
- Pay attention to the machine's work environment; do not subject it to atmospheric conditions.
- Do not install the machine in rooms that are dusty, where aerosols are sprayed, or to which oxygen is supplied.
- Keep the workplace well lit.
- Be careful of danger of electric shock.
- Pay attention to clothing. Let-down hair or loose clothing can be caught by the machine's mobile elements.
- Take care not to damage the power supply cable.
- When the machine is not in use, disconnect it from the power grid.
- Take care not to turn-on the machine accidentally.
- In case of even the slightest damage, always check if the damaged part requires replacement.
- Never install on the machine attachments and accessories other than those recommended by the manufacturer and supplier.
- Do not perform machine modifications independently.
- Do not leave near the machine unattended bystanders or children.

Electric installation

Check if the supply voltage in the electric socket corresponds to the data on the machine's rating plate 1-phase voltage 230V 50Hz.

Check the correctness of electric connections in the plug and electric socket, **observing electric shock safety countermeasures.**

Do not use extension power cords.

Apply the valid electrical and Industrial Safety norms.

ATTENTION – all work related to the electrical installation must be carried out by a qualified electrician.

Before starting work

Using machine without any of the safeguarding parts (finger guard, eye guard, etc.) is dangerous to an operator.

During work, only the items necessary for sewing should be found on the machine's work table.

Before connecting the machine to the power grid, always release the pedal and the start button.

Do not use blunt or bent needles.

Do not touch any of the machine's mobile elements, such as the needle, needle bar, thread tensioner or take-up, or hook, during its operation.

Turn machine off before: replacing needle, threading, installing attachments, changing the bobbin or bobbin case.

If you notice any abnormalities in the machine's function, turn it off immediately and inform a mechanic or your superior. After finishing work, turn the machine off and remove the plug from the electric socket. In case of power grid failure, disconnect the machine from the power grid.

This machine is not a toy!

We hope that you will use this machine with pleasure for a long time.

USER'S MANUAL

The overlock machines TEXI, model Tre 04 N, Quattro 24 N and Cinque 35 N, are high speed sewing machines, designed for sewing and serging woven or knitted materials or other textiles.

Attention!

The machine is not to be used for other materials than those for which it has been designed.

Non-observance of this rule places the user at risk and can cause irreversible damage to the machine.

Before use, the user should become acquainted with this instruction manual, general safety precautions and maintenance instructions.

1. Before starting work

1. After turning-on the machine and during its operation, do not touch the needle or other moving parts of the machine.
2. During sewing, do not put fingers into the needle guard.
3. Before uninstalling guards, turn power off.
4. Turn machine off before leaving it unattended.
5. Do not allow hair, loose clothing, fingers or any objects to be in the vicinity of the pulley during machine run.
6. Do not clean the machine with paint thinner.

Technical Specification

Model	Tre 04 N	Quattro 24 N	Cinque 35 N
Application	Light & medium materials	Light & medium materials	Light & medium materials
Power supply	230 V	230 V	230 V
Frequency	50 ~ 60 Hz	50 ~ 60 Hz	50 ~ 60
Number of Needles	1	2	2
Number of threads	3	4	5
Sewing speed (max)	7000 stitches per minute	7000 stitches per minute	7000 stitches per minute
Stitch Width	4 mm	6 mm	8 mm
Needle	B-27 with appropriate tips to the type of sewn materials	B-27 with appropriate tips to the type of sewn materials	B-27 with appropriate tips to the type of sewn materials
Lubricating oil	Oil for high speed machines	Oil for high speed machines	Oil for high speed machines
Nett weight	37 kgs	37 kgs	37 kgs
Packing dimension	515 × 360 × 466 mm	515 × 360 × 466 mm	515 × 360 × 466 mm

OBSERVE THIS SAFETY PRECAUTIONS

- To prevent accidents, do not remove safety devices or parts while operating the machine.
- Do not leave tools or other unnecessary objects on the machine table while operating the machine.
- Before maintenance, adjusting, cleaning, threading or replacing the needle, and to prevent accidents, be sure the power is off. Check that the machine will not operate when the pedal is pressed.
- Turn the power off before leaving the machine's table.
- In the event of power failure, be sure to turn the machine off.
- Check that the machine is securely grounded.

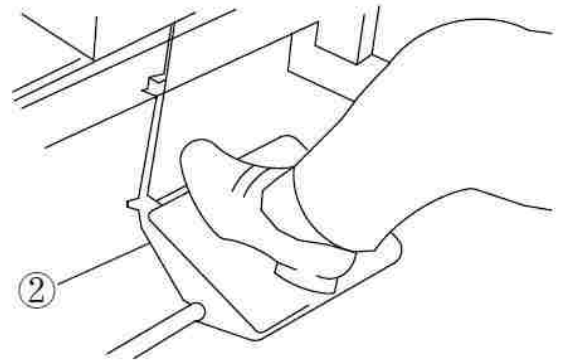
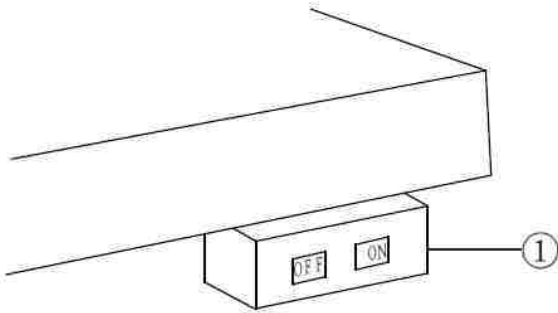

NOTE:

In case a crutch motor is used, it will keep on rotating by inertia after turning off the power supply (1). If the machine's pedal (2) is stepped on inadvertently, it is dangerous because the machine will move unexpectedly. Keep on stepping on the machine's pedal (2) until the machine comes to a stop after turning off power supply.

1. Assemble the machine head on the table top

2. Lubrication

After filling the oil reservoir, its level should lie between (H) and (L) lines.
Add oil when the oil level reaches or goes slightly below (L).

Note: Use special oil for high speed sewing machines

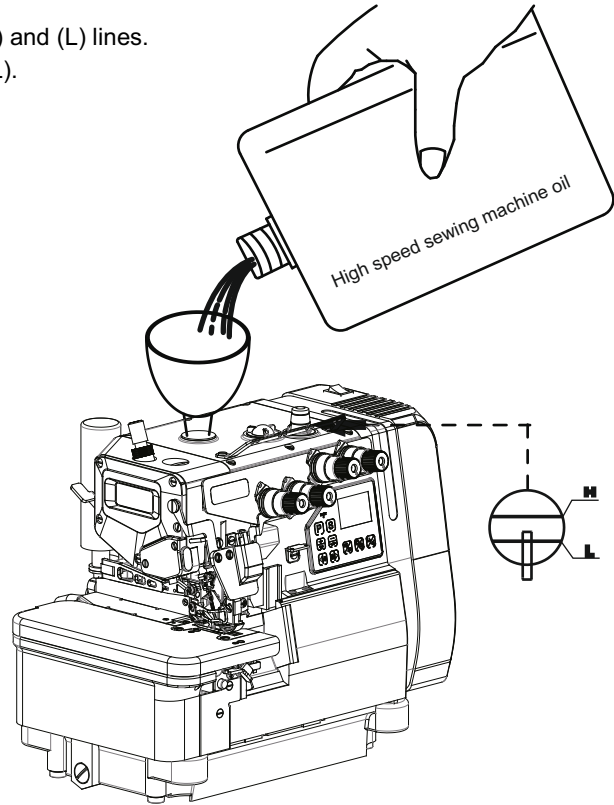

3. Manual Lubrication

Apply 2 or 3 drops of oil, by means of oil lubricator, before use if the machine for the first time or after a long idle time.

Note: Use special oil for high speed sewing machines

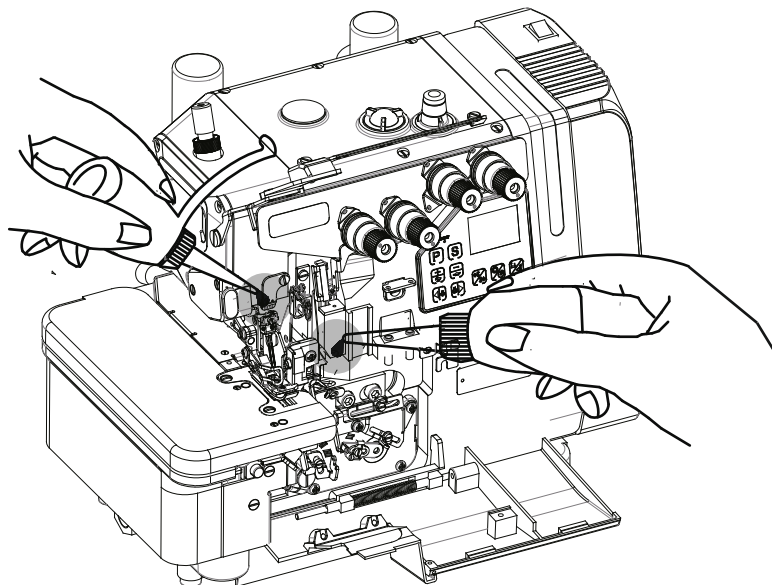

4. Filling in cans (grease fitting) devices with silicon oil

Fill the cans (grease fitting) devices with oil before it is too low in order to prevent needle thread breakage and fabric damage.

Note: Use recommended silicon oil.

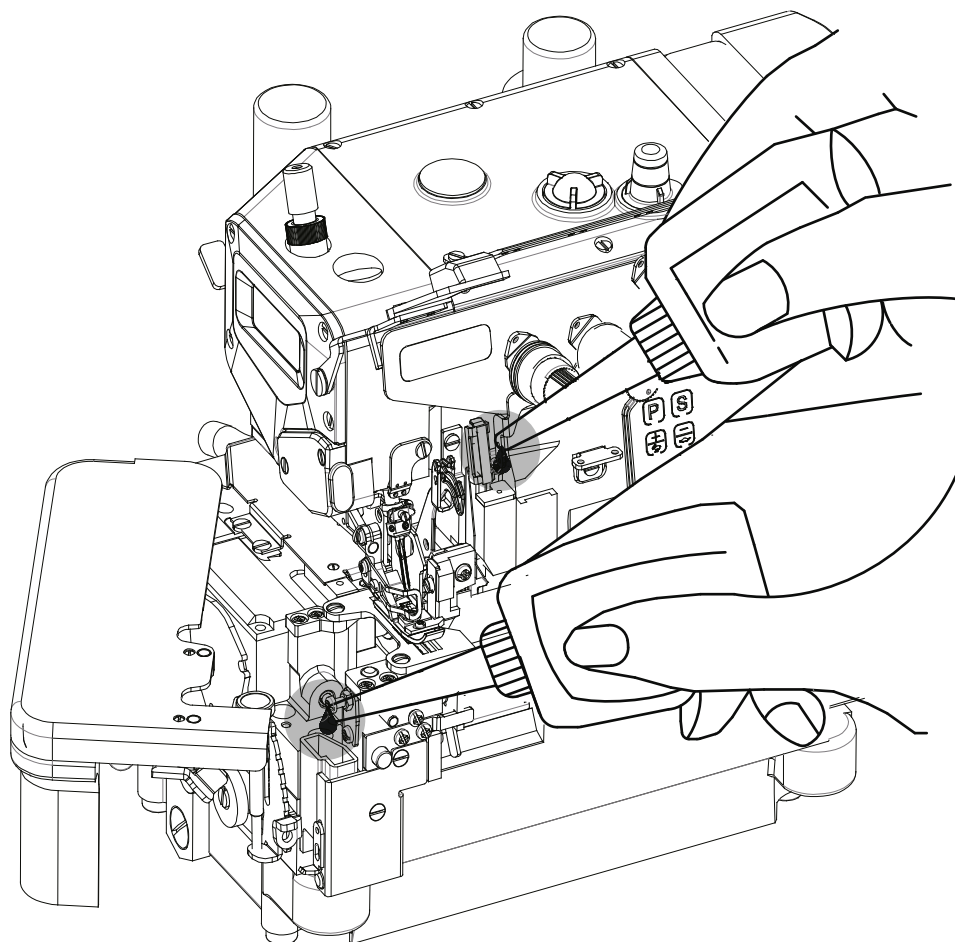

5. Threading

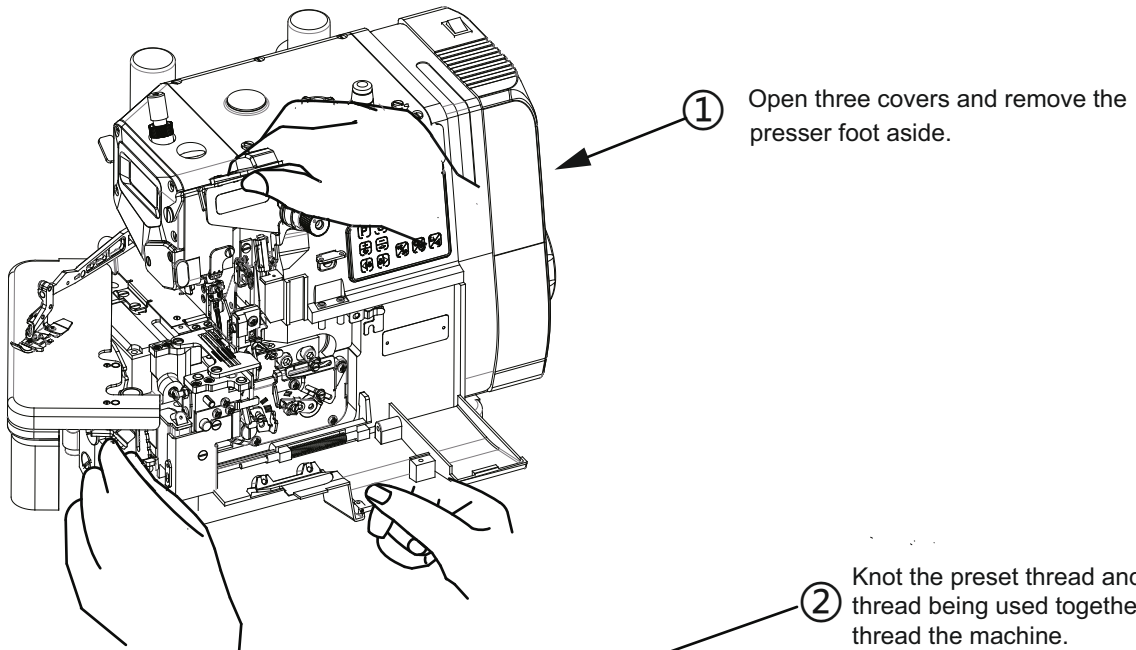

Needle thread

Trim the knots off neatly before passing through the eye of the needle to rethread

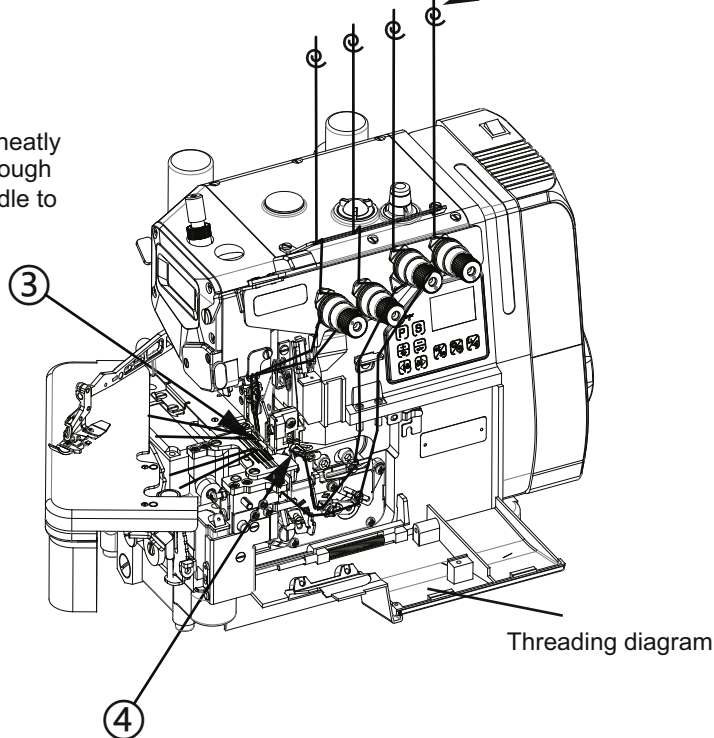

threaded correctly by referring to the threading diagram.

Looper thread

Trim the knots off neatly after passing through the eye of the looper.

6. Adjusting the presser foot pressure

Turn adjusting knob to adjust the presser foot pressure. It should be as light as possible, yet be sufficient to obtain the proper stitch formation

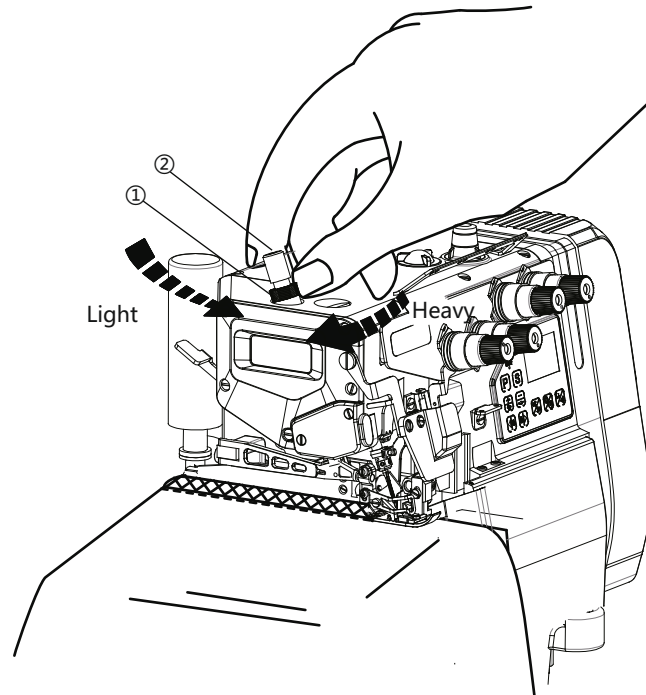

7. Adjusting the differential feed ratio

- If the stroke of the main transporter is bigger than the stroke of the differential transporter, the sewn material is stretched.
- If the stroke of the main transporter is smaller than the stroke of the differential transporter, the sewn material will be gathered.

Loosen the nut and move the lever up or down to obtain the correct differential feed ratio. Tighten the nut after positioning the lever as desired.

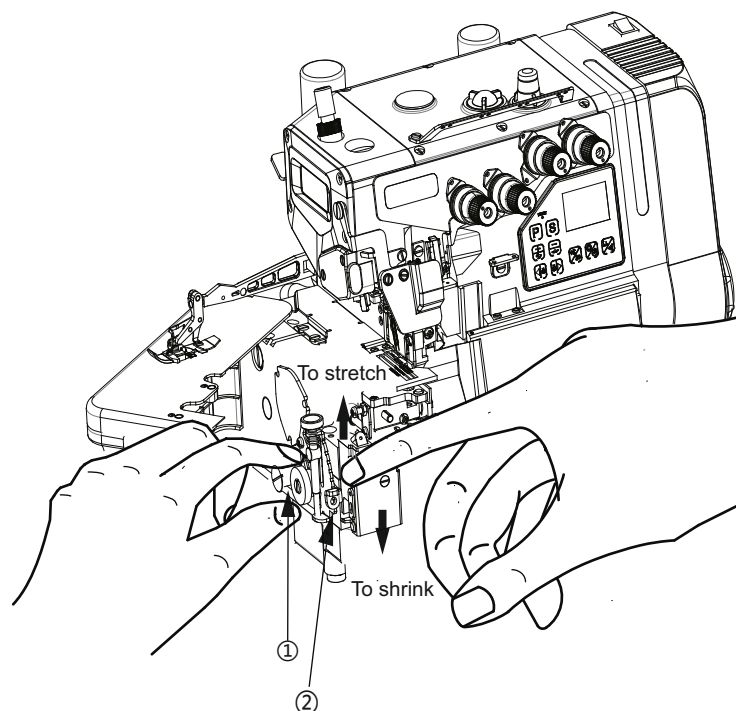

8. Replacing lower knife

To remove lower knife

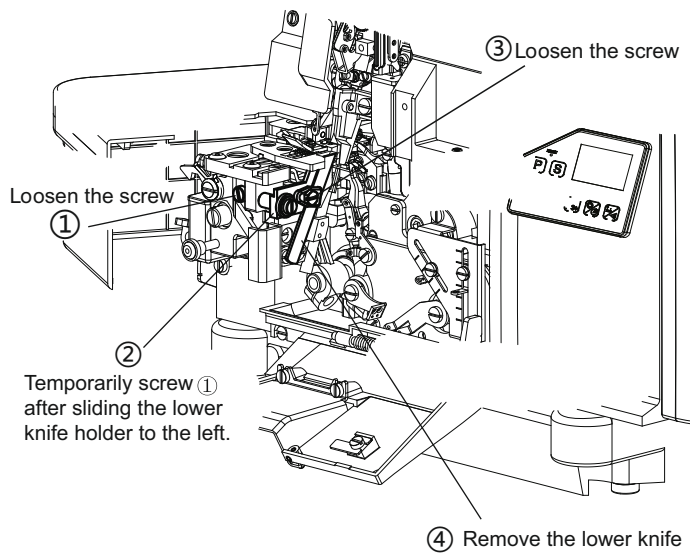

Correct angles to sharpen the lower knife

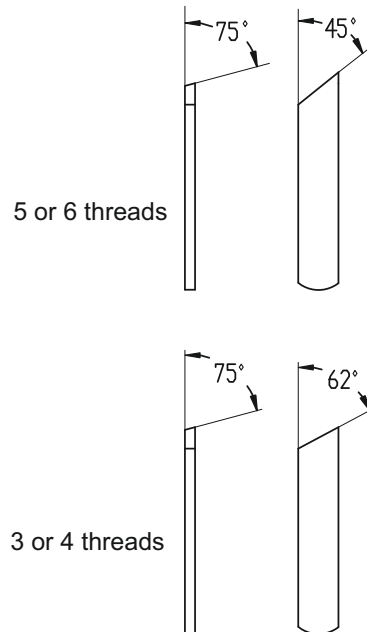

To replace lower knife

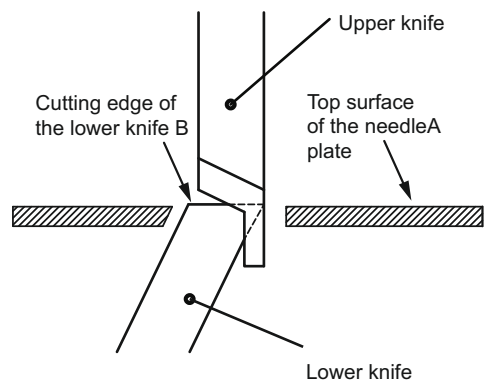
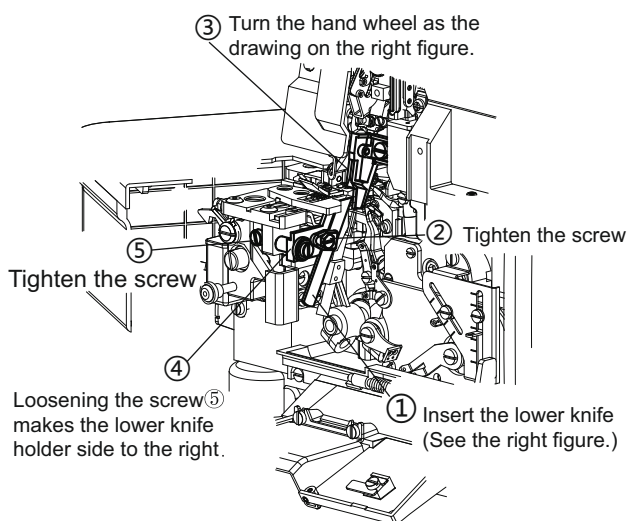

Level of [A]=Level of [B]

Check cutting action of knife.

9. Replacing the needle

- Check the needle carefully to see that the scarf is turned to the rear of the machine.
- Insert the needle to the proper depth, and fasten securely.
- Use the needle system B 27 with tip appropriate to the type of sewn material (see the "Ask your supplier about" section)

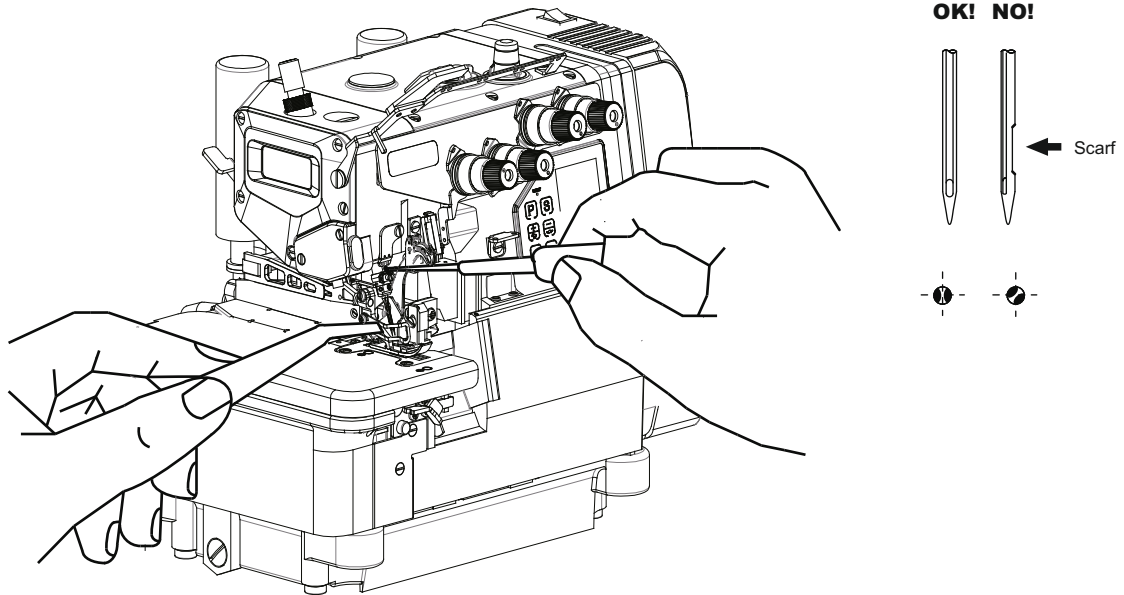

10. Adjusting stitch length

(1) While pressing the push button, turn the handwheel to seek the position at which the push button goes further into the depth.

(2) Then, keeping the push button pressed, turn the handwheel and set the desired scale to the aligning mark.

Note: Stitch length adjustment must only be made after the differential feed ratio has been changed

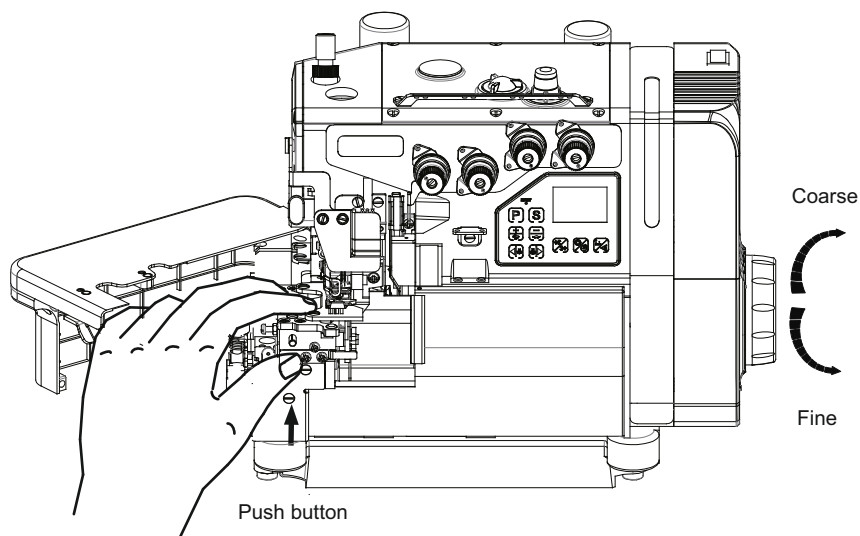

11. Replacing the oil and oil filter

Remove the screw and pour out the old oil from the machine. Then re-tighten the screw. Oil should be replaced a month after the start of machine operation and thereafter every six months.

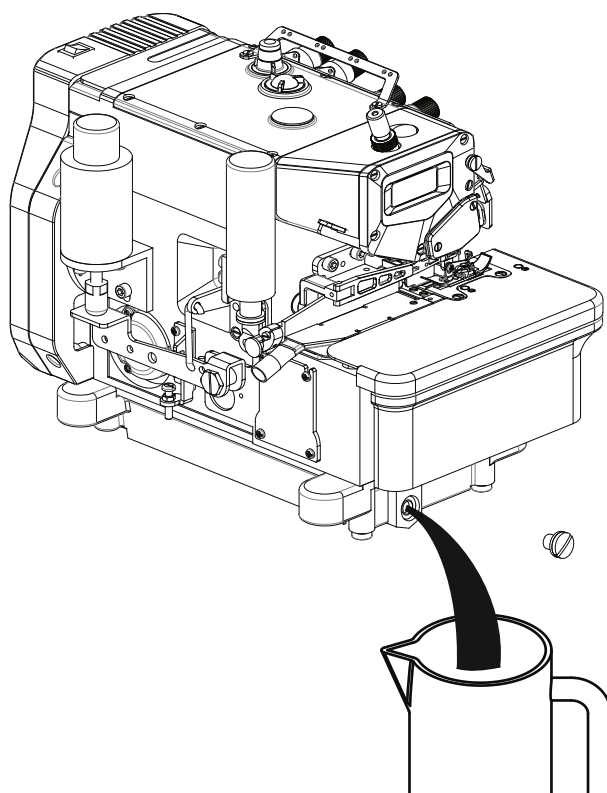

Check and replace the oil filter every six months.

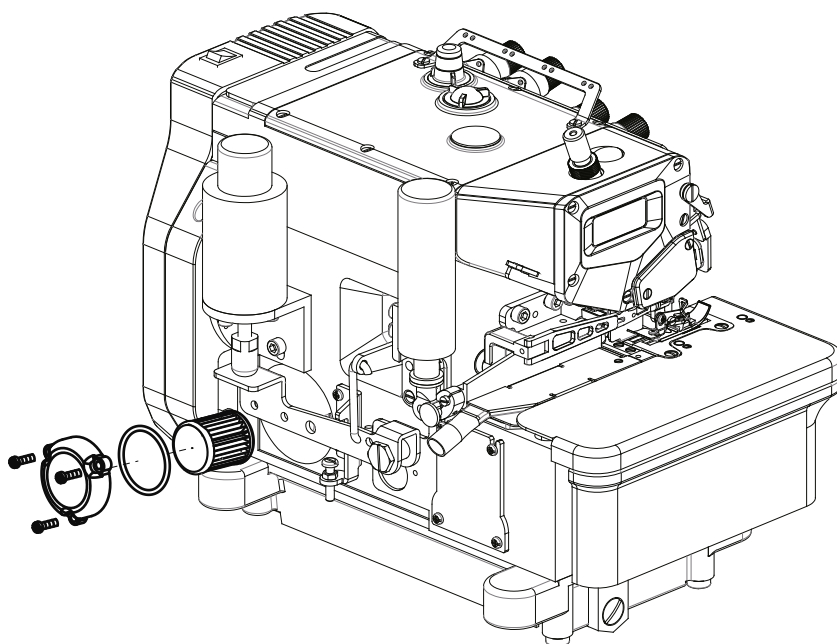

12. Adjusting thread tension

Make tension adjustment with the needle thread knob (1), upper looper knob (2), and lower looper knob (3).

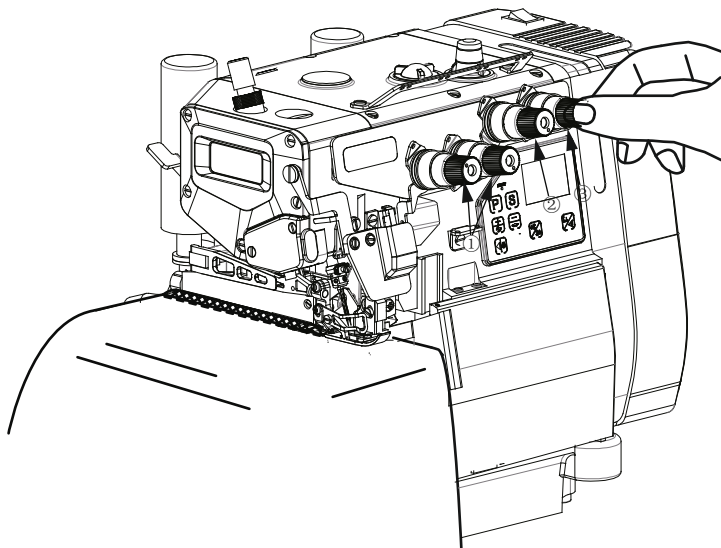
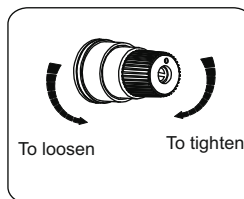

13. Cleaning the machine



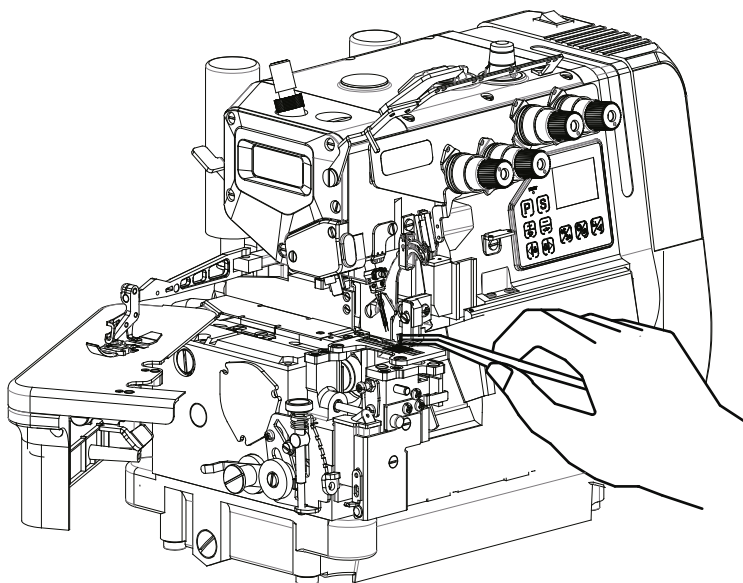

Mainly the slots of the needle plate and the feed rows should be cleaned regularly.









REGULATION



Attention: Any adjustment can be performed only by qualified personnel. Guards of the machinery, to be removed to allow the control and regulation, should be re-installed before restarting the machine.

Settings

					
	Needle bar height (mm)	Lower looper to needle clearance (mm)	Upper looper to needle clearance (mm)	Bottom transporter height (mm)	Fabric clearance (mm)
Tre 04 N	10.1	4.2	3.3	0.9 – 1.1	5.5
Quattro 24 N	10.6	4.2	3.3	0.9 – 1.1	5.5

						
	Needle bar height (mm)	Lower looper to needle clearance (mm)	Upper looper to needle clearance (mm)	Bottom transporter height (mm)	Fabric clearance (mm)	Chainstitch looper to needle clearance (mm)
Cinque 35 N	10.6	3.9	3.3	0.9 – 1.1	5.5	1.5

ASK YOUR SUPPLIER ABOUT:

	<p>Machine needle with tip adjusted to sewed material:</p> <p>R - round, standard tip for most fabrics. SPI - very slim, acute tip, for a precise piercing of densely woven materials. SES - light ball point, especially suitable for jersey, tricot, elastic woven materials. SUK - medium ball point, best corsetry, jeans, coarse knitted fabrics and also elastic materials.</p>
	<p>TERESSTIC T32</p> <p>High class oil for high-speed machines as overlock and coverstitch machines. Based on mineral oil. Used for central and point lubrication.</p>
	<p>SPIRIT 37</p> <p>Silicon fluid modified especially for textile industry. Used for preparation of sewing thread and yarn, lubrication of knitting machine needles. Colourless and odourless. Applied with brushm sprinkle or through immersion.</p>
	<p>TWE6</p> <p>Tweezers</p>

CE DECLARATION OF CONFORMITY

Distributor:

Strima Sp. z o.o.

Swadzim, ul. Poznańska 54

62-080 Tarnowo Podgórne, Poland

We declare, that the following product:

Overlock High Speed Machine

Tre 04 N (ZJ-B9500-17-02)

Quattro 24 N (ZJ-B9500-13H-02)

Cinque 35 N (ZJ-B9500-38-02)

With this declaration relates, complies with following directives:

Machine directive 2006/42/EC

Low voltage directive 2014/35/EU

Harmonized norm used: EN 60204-31:2013



Dealer :

--